

**NATIONAL ELECTROSTATICS CORP.**

Instruction Manual No. 2HT018000 for  
Operation and Service of

FIBER OPTIC DATA TELEMETRY SYSTEM

2HA018000

3/22/19  
SJL2

## TABLE OF CONTENTS

I.	SCOPE OF THE MANUAL	1.1
II.	THEORY OF OPERATION	2.1
	2.1 Uses for the system	2.1
	2.2 Principles of operation	2.1
III.	MECHANICAL CONFIGURATIONS	3.1
	3.1 Circuits	3.1
	3.1.1 Optical Transmitter for Analog Signals	3.2
	3.1.2 Optical Receiver for Analog Signals	3.2
	3.1.3 Optical Transmitter for Status Signals	3.4
	3.1.4 Optical Receiver for Status Signals	3.5
	3.1.5 Optical Receiver for Status-High Power Contacts	3.6
	3.1.6 Optical Receiver/Transmitter for Analog/Status Signals	3.6
	3.2 Chassis Sizes	3.7
	3.2.1 Size 1	3.7
	3.2.2 Size 2	3.8
	3.2.3 Size 3	3.9
	3.2.4 Size 4 - Optical Chassis Only	3.10
	3.2.5 Size 4 - Power Supply Only	3.11
	3.3 Connections	3.12
	3.4 System Configuration	3.15
IV.	CIRCUIT DESCRIPTIONS	4.1
	4.1 Optical Transmitter for Analog Signals	4.1
	4.2 Optical Receiver for Analog Signals	4.1
	4.3 Optical Transmitter for Status Signals	4.2
	4.4 Optical Receiver for Status Signals	4.3
	4.5 Optical Receiver for Status-High Power Contacts	4.3
	4.6 Optical Receiver/Transmitter for Analog/Status Signals	4.4
	4.7 Power Supply - Size 1, 2	4.4
	4.8 Power Supply - Size 3, 4	4.5
	4.9 Power Supply - Referenced	4.6
V.	OPERATING PROCEDURES	5.1

VI.	FIBER PREPARATION	6.1
	6.1 External Fiber Optic Cables	6.1
	6.2 Internal Fiber Optic Cables	6.3
	6.2.1 Optic Interlink Cable Connector End	6.3
	6.2.2 Optic PCB Connector End	6.5
VII.	APPENDICES	7.1
	7.1 Summary	7.1
	7.2 Drawings and Schematics Listing	7.2
	7.3 NEC Fiber Optic Data Telemetry System Configuration	7.3

## **ELECTRICAL SAFETY INSTRUCTIONS**



**IMPORTANT SAFETY INFORMATION  
READ BEFORE OPERATION AND SERVICE**



**SHOCK HAZARD WARNING  
THIS UNIT USES AC MAINS POWER  
THIS UNIT CONTAINS DANGEROUS VOLTAGES AND ENERGY**

This unit must only be operated and serviced by qualified personnel who have read the instruction manual and are familiar with the hazards associated with dangerously high voltages. Proper care and judgment must always be observed.

### **OPERATION:**

1. Before connecting input AC power, ensure that all covers are in place and securely fastened. Ensure that the required safety ground to the chassis is installed (indicated by the protective ground symbol) and sufficient cooling is supplied.
2. Proper grounding from the input AC power is required to reduce the risk of electric shock and to comply with safety agency and code requirements.
3. Use caution when connecting input AC power. Only apply the input voltage specified on the rating label.
4. Use caution when connecting any high voltage cables. Never handle any output cables while the unit is energized.
5. After the unit is switched off, dangerous voltages may remain on the outputs. Allow sufficient time for self-discharge before handling anything connected to an output. The user's load must be taken into consideration when determining the time required. Use a mechanical ground when possible.
6. When user serviceable fuses are present, always replace fuses with the same type and volt/amp rating.
7. Never attempt to operate the unit in any manner not described in the instruction manual.
8. Never remove warning labels from the unit. Immediately replace lost or damaged labels. Contact NEC for any replacement labels.

## **SERVICE:**

The following safety labels apply to this unit:



**CAUTION - Risk of electrical shock**



**Protective Ground Conductor**

1. Service is best done by NEC trained technical personnel, either at the site during installation or by returning the unit to the NEC factory. Call NEC at 608-831-7600 for a Return Materials Authorization (RMA) number and ship unit to 7540 Graber Road, Middleton, WI 53562.
2. If service of this unit is to be done at the user's site, this service may only be performed by trained and qualified personnel and must follow instructions from this manual or from NEC technical personnel.
3. Consult NEC supplied assembly drawings, parts lists, circuit board drawings and schematic diagrams for service details.

## I. **SCOPE OF THE MANUAL**

This manual is intended for use with the Fiber Optic Data Telemetry System manufactured by National Electrostatics Corp. The scope of this manual covers theory of operation, mechanical details, circuit description, installation and operation, and fiber preparation.

## II. THEORY OF OPERATION

### 2.1 Uses for the System

The Fiber Optic Data Telemetry System offers complete electrical isolation between reference levels differing by kilovolts to megavolts. The system is rugged enough for use in high electromagnetic interference environments. The system is able to transmit analog and logic signals for distances up to 100 feet. The analog signals may be highly sensitive 100 mV, or standard 0 to +10 VDC or -10 to 0 VDC signals. The logic (status) signals may be voltage sense control or contact closures.

### 2.2 Principles of Operation

The Fiber Optic Data Telemetry System offers many configurations for maximum flexibility depending upon the number and type of signals to be used. The system is based on four standard primary and two standard secondary circuits listed below.

OTA - Optical Transmitter for Analog Signals accepts a 0-10 VDC analog signal and converts it to a 1K to 10 KHz light modulated signal. The input impedance is 1M ohm.

ORA - Optical Receiver for Analog Signals receives a 1 K to 10 KHz light modulated signal and converts it to a 0-10 VDC analog signal.

OTS - Optical Transmitter for Status Signals either accepts a voltage input or senses a contact closure/opening. The status is converted into a 5 KHz light modulated signal.

ORS - Optical Receiver for Status Signals receives a 5 KHz light modulated signal and either outputs a voltage or closes a set of relay contacts. Output voltage is either +24 VDC or TTL. Contacts are limited to 0.5 A and 10 W.

ORSHP - Optical Receiver for Status - High Power Contacts receives a 5 KHz light modulated signal and opens a set of relay contacts. In addition, it either outputs a voltage or closes a set of relay contacts. Output voltage is +24 VDC. Contact rating is up to 1 Amp at 120 VAC.

ORTAS - Optical Receiver/Transmitter for Analog/Status signals contains one channel of each type (OTA, ORA, OTS, ORS) discussed above.



### III. MECHANICAL CONFIGURATIONS

#### 3.1 Circuits

The four basic circuits OTA, ORA, OTS, ORS have a designed capability for input or output modifications. The modifications are dependent on the board usage.

##### 3.1.1 Optical Transmitter for Analog Signals (OTA)

The standard OTA circuit board has 4 channels, each identical but separate. Each OTA channel normally accepts 0 to +10 VDC, but modifications are available for negative polarity and smaller signal excursions.

For positive input voltages ARX01-A is an inverting amplifier where RX01 and RX04 are inserted as shown in Figure 3.1a. For negative input voltages ARX01-A is a non-inverting amplifier where RX16, RX17, RX18 are inserted as shown in Figure 3.1b.

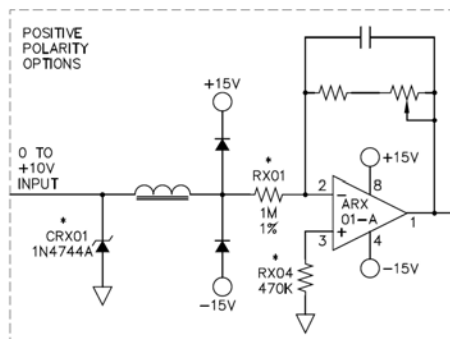

Figure 3.1a

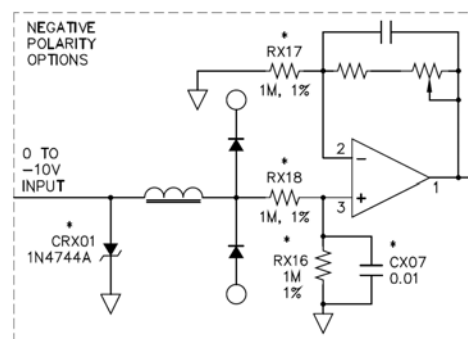

Figure 3.1b

For input voltages other than 10 VDC full scale, the following equations are helpful in determining resistance values.

### Positive Input

$$RX01 = VIN \times 10^5$$

$$RX04 = (RX01 \times 10^6)/(RX01 + 10^6)$$

### Negative Input

$$RX18 = -VIN \times 10^5$$

$$RX16 = 1M \text{ (typical)}$$

$$RX17 = RX18$$

$$CX07 = 0.01 \text{ UF (typical)}$$

NOTE: All input signals must be referenced to the same common potential as the light link chassis.

#### 3.1.2 Optical Receiver for Analog Signals (ORA)

The standard ORA circuit board has 4 channels, each identical but separate. Each ORA channel normally outputs 0 to +10 VDC, but modifications are available for negative polarity and smaller signal excursions.

For positive output voltages ARX01-B is an inverting amplifier where RX15 and RX18 are inserted as shown in Figure 3.2a. For negative output voltages ARX01-B becomes a non-inverting amplifier where RX20, RX21, RX22 and CX10 are inserted as shown in Figure 3.2b.

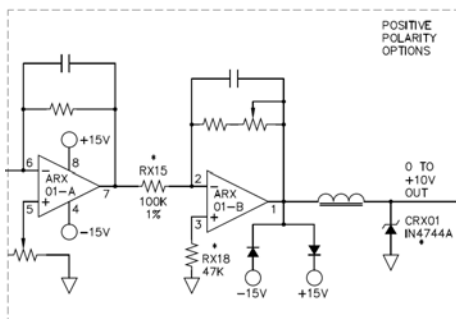

Figure 3.2a

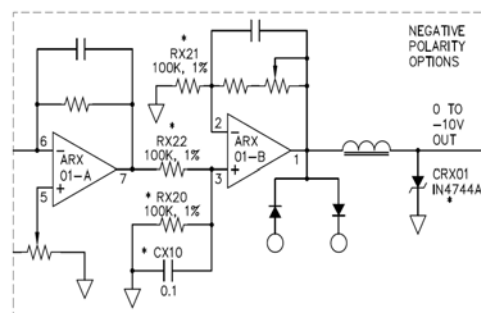

Figure 3.2b

For output voltages other than 10 VDC full scale, the following equations are helpful in

determining resistance values.

#### Positive Output

$$RX15 = 10^6/V_{out}$$

$$RX18 = (RX15 \times 10^5)/(RX15 + 10^5)$$

#### Negative Output

$$RX20 = 100K \text{ (typical)}$$

$$RX21 = -10^6/V_{out}$$

$$RX22 = RX21$$

$$CX10 = 0.1 \mu F \text{ (typical)}$$

NOTE: All output signals must be referenced to the same common potential as the light link chassis .

### 3.1.3 Optical Transmitter for Status Signals (OTS)

The standard OTS circuit board has 6 channels, each identical but separate. Each OTS channel can sense a contact closure, a contact opening or +24 VDC input.

- To sense a normally open (NO) contact, the jumpers JX1 and JX2 are inserted in the 'CC' positions as shown in Figure 3.3a.
- To sense a normally closed (NC) contact, the jumper JX1, 'CC' and resistors RX12 and RX13 are inserted as in Figure 3.3b.
- To sense an input voltage, the jumpers JX1 and JX2 are inserted in the 'V' positions as shown in Figure 3.3c.

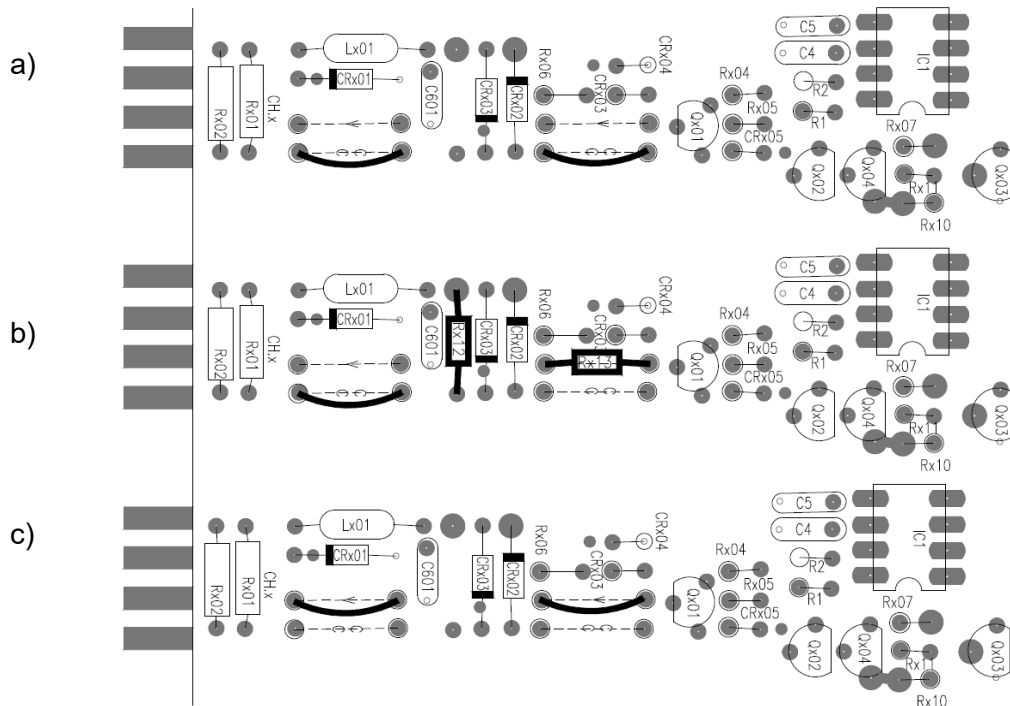

### 3.1.4 Optical Receiver for Status Signals (ORS)

The standard ORS circuit board has 6 channels, each identical but separate. Each ORS channel can close a normally open relay contact, or output a +24 VDC signal.

d) For a normally open (NO) contact output, the jumper JX1 is installed as shown in

Figure 3.4a.

e) For a +24 VDC output, both the jumpers JX2 and JX3 are to be installed as shown in

Figure 3.4b.

f) For a TTL output, both the jumper JX3 is installed and a resistor of value 3.9k ohms is installed in JX2 as shown in Figure 3.4c.

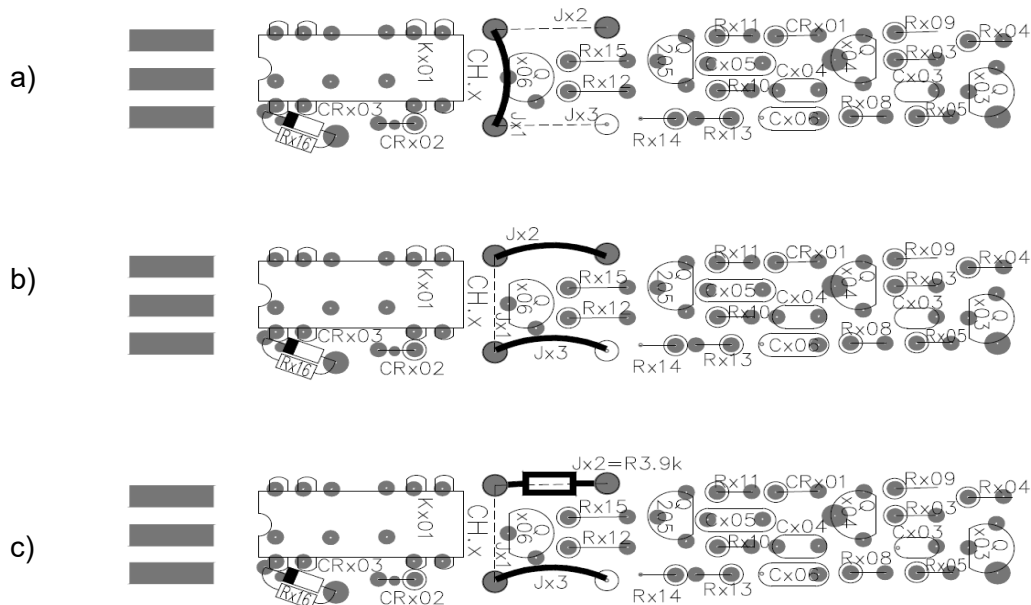

Figure 3.4

### 3.1.5 Optical Receiver for Status Signals High Power (ORSHP)

The standard ORSHP circuit board has 6 channels, each identical but separate. Each ORSHP channel has the same modifications available as the ORS (see section 3.1.4). In addition, it provides a second output of opening of a relay contact. The board requires 2 slot positions due to the increased height profile of the relays.

### 3.1.6 Optical Receiver/Transmitter for Analog/Status Signals (ORTAS)

The standard ORTAS circuit board has 4 channels, one each of the OTA, ORA, OTS, ORS on a single circuit board. The board has all options that the individual circuits have. Please refer to drawing number 2HS049280 for details.

## 3.2 CHASSIS SIZES

The Fiber Optic Data Telemetry system is available in four chassis sizes to meet varying requirements of channel count. The sizes are numbered 1, 2, 3, 4. The size is chosen and configured to propagate all necessary signals between the voltage levels.

### 3.2.1 Size 1 Chassis

External Dimensions: 4" x 4" x 8"

Number of Slots: 1

2HA049370

Power: 115/230 VAC, 50/60 Hz, 15 W

2HA057330

Terminal, EU, Power: 120 VAC, 400 Hz, 15 W

The Size 1 chassis is the smallest of the four. The chassis contains a power supply and a slot for one signal processing board (OTA, ORA, OTS, ORS, ORTAS). The ORSHP will not fit in the Size 1 chassis due to relay height. See Section 4.5.

Chassis-mounted connectors include an optical cable connector, a 15-pin electrical signal connector, and a power input connector.

### 3.2.2 Size 2 Chassis

External Dimensions: 4" x 6" x 8"

Number of Slots: 2

2HA034660

Power: 115/230 VAC, 50/60 Hz, 25 W

2HA057340

EU, Power: 115/230 VAC, 50/60 Hz, 25 W

2HA057540

Terminal, EU, Power: 120 VAC, 400 Hz, 25 W

The Size 2 chassis contains a power supply and slots for two signal processing boards (OTA, ORA, OTS, ORS, ORTAS). The ORSHP can be used if that is to be the only board, due to the height of the relays. See Section 4.5. The combinations of board types are listed below.

----- Boards -----			Total Channels
4 Channel	6 Channel	ORSHP	
2	0	0	8
1	1	0	10
0	2	0	12
0	0	1	4

Chassis-mounted connectors include an optical cable connector, a 25-pin electrical signal connector and a power input connector.



### 3.2.3 Size 3

External Dimensions: 4" x 8" x 8"

Number of Slots: 4

2HA057550

EU, Power: 115/230 VAC, 50/60 Hz, 40 W

2HA057560

Terminal, EU, Power: 120 VAC, 400 Hz, 40 W

The Size 3 chassis contains a power supply and slots for four signal processing boards (OTA, ORA, OTS, ORS, ORTAS). If an ORSHP board is used then one less board may be used for each ORSHP installed. See Section 4.5. The combinations of board types are listed below.

----- Boards -----			Total Channels
4 Channel	6 Channel	ORSHP	
4	0	0	16
3	1	0	18
2	2	0	20
1	3	0	22
0	4	0	23*
0	0	2	8
0	2	1	10
2	0	1	8
1	1	1	14

\*Optical connector has only 23 positions, so one board can use only 5 channels.

Chassis-mounted connectors include an optical cable connector, two 25-pin electrical signal connectors, and a power input connector.

### 3.2.4 Size 4 - Optical Chassis

External Dimensions: 4" x 8" x 8"

Number of Slots: 8

2HA056060

Power Requirements: +24 VDC, +15 VDC, -15 VDC, +5VDC

The Power is Supplied from a separate Size 4 chassis.

The Size 4 Optical Chassis does not contain the unit power supply. For the companion power supply see section 3.2.5. There are 8 slots for 8 signal processing boards unless an ORSHP board is used. See Section 4.5. The combinations of board types are listed below.

4 Channel	Boards 6 Channel	ORSHP	Total Channels
8	0	0	32
7	1	0	34
6	2	0	36
5	3	0	38
4	4	0	40
3	5	0	42
2	6	0	44
1	7	0	46
6	0	1	34
5	1	1	30
4	2	1	32
3	3	1	34
2	4	1	36
1	5	1	38
0	6	1	37
4	0	2	24
3	1	2	26
2	2	2	28
1	3	2	30
0	4	2	32

Chassis-mounted connectors include two optical cable connectors, four 25-pin electrical signal connectors and a DC power connector.

### 3.2.5 Size 4 - Power Supply

External Dimensions: 4" x 8" x 8"

2HA057280

Terminal, EU, Power: 120 VAC, 400 Hz 80 W

2HA057290

EU, Power: 115/230 VAC, 50/60 Hz 80 W

The Size 4 Power Supply Chassis provides the power requirements for the Size 4 Optical Chassis.

Chassis-mounted connectors include an AC input power connector and a DC output power connector which carries the +24 VDC, +15 VDC, -15 VDC, and +5 VDC as well as the circuit common. Use Power Interconnect cable # 2HA05607x, where the x specifies the length.

### 3.3 CONNECTORS

There are several chassis-mounted connectors on the various Fiber Optic Data Telemetry System chassis that have multi-pin connections. These include the optical connectors and electrical connectors. It may be helpful to refer to drawings listed in Appendix 7.2 labeled:

- Optic Chassis Assembly Configuration - for electrical connections.
- Optic Cable Assembly Configuration - for external fiber cable.

#### Optical Connector:

AMP #202786-2 23-pin, positive locking connector. There are 23 possible fiber locations. The Optic Cable Assembly drawing details each fiber signal as well as the fiber position.

#### Electrical Connectors:

- Size 1: 15-pin subminiature-D connector see table 3.1
- Size 2,3,4: 25 pin subminiature-D connector see Table 3.2

The electrical connections are all detailed in Optic Chassis Assembly configuration. This layout tells the type of board (analog or status) in each slot and which electrical signal is connected to each pin of the connectors. Additionally, status boards indicate the type of input or output expected.

Table 3.1 15-pin Electrical Connector Pin Out Of Size 1

<u>Pin No.</u>	<u>Analog (OTA, ORA, ORTAS)</u>	<u>Status (OTS, ORS)</u>
1	Channel 1 signal	Channel 1 signal
9	Channel 1 com	Channel 1 com
2		Channel 2 signal
10		Channel 2 com
3	Channel 2 signal	Channel 3 signal
11	Channel 2 com	Channel 3 com
4		Channel 4 signal
12		Channel 4 com
5	Channel 3 signal	Channel 5 signal
13	Channel 3 com	Channel 5 com
6	Channel 4 signal	Channel 6 signal
14	Channel 4 com	Channel 6 com
7		
15		
8	Shield	Shield

Table 3.2 25-pin Electrical Connector Pin Out of Sizes 2 thru 4

<u>Pin Out Analog (OTA, OTS, ORTAS)</u>		<u>Status (OTS, ORS, ORSHP)</u>		
Slots 1,3,5, 7	1 Channel 1 signal	Channel 1 sig	\ or contact pair	
	14 Channel 1 com	Channel 1 com	/	
	2	Channel 2 sig	\ or contact pair	
	15	Channel 2 com	/	
	3 Channel 2 signal	Channel 3 sig	\ or contact pair	
	16 Channel 2 com	Channel 3 com	/	
	4	Channel 4 sig	\ or contact pair	
	17	Channel 4 com	/	
	5 Channel 3 signal	Channel 5 sig	\ or contact pair	
	18 Channel 3 com	Channel 5 com	/	
	6 Channel 4 signal	Channel 6 sig	\ or contact pair	
	19 Channel 4 com	Channel 6 com	/	
	Slots 2,4,6 8	7 Channel 1 signal	Channel 1 sig	\ or contact pair
		20 Channel 1 com	Channel 1 com	/
		8	Channel 2 sig	\ or contact pair
		21	Channel 2 com	/
		9 Channel 2 signal	Channel 3 sig	\ or contact pair
		22 Channel 2 com	Channel 3 com	/
		10	Channel 4 sig	\ or contact pair
23		Channel 4 com	/	
11 Channel 3 signal		Channel 5 sig	\ or contact pair	
24 Channel 3 com		Channel 5 com	/	
12 Channel 4 signal		Channel 6 sig	\ or contact pair	
25 Channel 4 com		Channel 6 com	/	
13 Shield		Shield		

### 3.4 SYSTEM CONFIGURATION

Each signal required to cross the voltage potential is named and specified by type and range. Circuit boards are configured to accommodate all the signals and any reference voltages necessary. Refer to Optical Chassis Configuration Template on page 7.4.

When both uplink (ground) and downlink (high voltage) chassis are defined, the interconnecting optic cable is determined. Refer to Optical Cable Template on page 7.5.

For the particular design of any Light Link (LL) system, refer to the three '2HA0.....' drawings for that specific system.

#### IV. CIRCUIT DESCRIPTIONS

##### 4.1 OPTICAL TRANSMITTER FOR ANALOG SIGNALS (OTA)

The OTA circuit board (schematic 8-3454) has 4 separate transmitter circuits, each identical. The standard OTA channel receives a 0 to +10 VDC signal into a 1M input impedance. ARX01-A buffers and inverts the signal. RX03 is the GAIN ADJUST, for the upper limit. ARX01-B is a range limiting inverting amplifier. RX08 is the ZERO ADJUST for the lower limit. The range limited output is .21 V to 9.95 V for the voltage to frequency converter, I1, which is an NEC designed hybrid. At its heart, it uses a T.I. VFC32KU for Voltage/Frequency conversion and delivers an output square wave with a frequency range of 1 to 10 kHz. While the signal frequency is set to 10 kHz maximum, the pulse width is only 25  $\mu$ sec. The output signal is directed through QX01 and QX02 buffering the IC and augmenting the current drive. The two transistors give a non-inverted output drive to the LED (CRX04) for the fiber optic cable.

##### 4.2 OPTICAL RECEIVER FOR ANALOG SIGNALS (ORA)

The ORA circuit board (schematic 8-3455) has 4 separate receiver circuits, each identical. The standard ORA channel receives an optical signal through phototransistor QX01, which turns on with light. When QX01 is on, it biases QX02 into conduction which pulls the base of QX03 down near ground, turning QX03 off. Once QX03 is off, QX04 turns off forcing a low pulse at pin 6 of I1, the frequency to voltage converter, which is an NEC designed hybrid. At it's heart, it uses a T.I. VFC32KU for Frequency/Voltage conversion and it converts the 1 to 10 kHz input signal to a corresponding 0 to +10VDC voltage.



ARX01-A buffers and inverts the output, while RX12 is used to ZERO ADJUST the output. ARX01-B also inverts and adds gain by GAIN ADJUST, RX17. The final output is the standard 0 to +10 VDC. Maximum current drive from the output is 10 mA.

#### 4.3 OPTICAL TRANSMITTER FOR STATUS SIGNALS (OTS)

The OTS circuit board (schematic 2HS039160) has 6 separate transmitter circuits, each identical, and a single frequency 5 kHz source. The frequency source is a 555 IC timer (T.I.). The frequency is set by RX01, RX02 and CX04 as is the pulse-width (10 $\mu$  seconds). There are three input options available, normally-open contact closure, normally-closed contact opening or a +24 VDC voltage sense.

For sensing closure of a normally-open contact, the junction between RX05 and RX06 is grounded which cuts off the base of transistor QX02. The voltage at the collector of QX02 increases to 0.7 V which turns on QX03. Transistor QX03 is now enabled, ready to drive the LED. QX04 is driven from the 5 KHz frequency source, its collector current directly driven to the base of QX03. QX03 drives the output LED, CRX06, which in turn drives the optical fiber.

For sensing the opening of a normally-closed contact, current through RX12, RX13, and RX03 is sensed by QX01. QX01 then grounds the junction between RX05 and RX06, which cuts off the base of QX02. The voltage at the collector of QX02 increases to 0.7 V which turns on QX03. Transistor QX03 is now enabled, ready to drive the LED. QX04 is driven from the 5 KHz frequency source, its collector current directly driven to the base of QX03. QX03 drives the output LED, CRX06, which in turn drives the optical fiber.

For a voltage sense input, a voltage input turns on QX01 which then grounds the junction between RX05 and RX06. The ground point cuts off the base of QX02. The voltage at the collector of QX02 increases to 0.7 V which turns on QX03. Transistor QX03 is now enabled, ready to drive the LED. QZ04 is driven from the 5 kHz frequency source, its collector current directly driven to the base of QX03. QX03 drives the output LED, CRX03 which in turn drives the optical fiber.

#### 4.4 OPTICAL RECEIVER FOR STATUS SIGNALS (ORS)

The ORS circuit board (schematic 2HS039170) has 6 separate receiver circuits, each identical. The ORS channel receives an optical signal through phototransistor QX01, which turns on. When QX01 is conducting, it biases QX02 into conduction, which pulls the base of QX03 low, turning it off. With QX04 off, the cathode of CRX01 lowers its voltage, allowing conduction. The diode current lowers the base voltage of QX05 turning it on. QX05 then turns on QX06 and relay KX01. Transistors QX02, QX03, and QX04 give the needed amplification and bandwidth for the optical signals. The losses due to traveling the fiber require both high gain and a large bandwidth.

#### 4.5 OPTICAL RECEIVER FOR STATUS - HIGH POWER CONTACTS (ORSHP)

The ORSHP circuit board (schematic 2HS039170) has 6 separate receiver circuits, each identical. The circuit works the same as the ORS, except the output relays are higher power (1 Amp at 120 VAC) and they have a second normally-closed output. Because the relays are larger, the board requires two slot positions in the chassis.

#### 4.6 OPTICAL RECEIVER/TRANSMITTER FOR ANALOG/STATUS SIGNALS (ORTAS)

The ORTAS circuit board (schematic 2HS049280) has 4 separate circuits, one each of the OTA, ORA, OTS, ORS. The individual circuits operate in the same manner as described in the previous sections.

#### 4.7 POWER SUPPLY - SIZE 1, SIZE 2

The Size 1,2 power supply (schematic 2HS039140) provides +24, +15, -15 and +5 VDC referenced to common circuit ground. The +5 VDC is regulated with a maximum output current of 0.35 Amp. The  $\pm 15$  VDC are regulated but the +24 VDC is unregulated; the combined output current of these 3 supplies must not exceed either 0.3 Amp or 0.8 Amp, depending on the model.

The power supply has 115 VAC, 50-400 Hz input into two transformers. One transformer is for the +24, +15, -15 VDC supplies; the other is for the +5 VDC supply. Transformer T1 (for +24, +15, -15 VDC) has a 36 VCT output to CR10, a bridge rectifier. The supply is configured in a dual complementary type with the transformer center tap grounded. The voltages are filtered by capacitors and each of the  $\pm 15$  VDC outputs are regulated by integrated circuits: a 7815 (+15 V) and a 7915 (-15 V). The +5 VDC supply has a full-wave center tap circuit from a 16 VCT transformer (T2). The circuit ground is connected to the center tap. The output is capacitively filtered and then regulated with a 7805.

#### 4.8 POWER SUPPLY - SIZE 3, SIZE 4

The Size 3,4 power supply (schematic 2HS039150) offers a +24, +15, -15 and +5 VDC referenced to common circuit ground. The  $\pm 15$  VDC and +5 VDC are regulated and short-circuit protected. The +24 VDC is unregulated. The combined current of these three supplies must not exceed either 1.5A or 2.8A, depending on the model.

The power supply takes a 115 VAC, 50-400 Hz input into two transformers. One transformer, T1, is for the +24, +15, -15 VDC supplies. It also handles any Reference Voltage (see Section 4.9). It is a 36 VCT transformer, with circuit ground tied to the center tap. The  $\pm 15$  VDC are configured as a dual complementary output from T1. Which output is sent through a bridge rectifier and capacitively filtered. The -15 VDC is simply output by I2, a 7915 voltage regulator.

The +15 VDC is controlled by I1, a 7815 voltage regulator, but having an addition of a current bypass transistor, Q1. Current is sensed through R10 and as the load increases beyond 45m Amp, it turns on Q1 to supply additional current. CR13 limits the voltage across R10 to 4.7 Volts, which limits current through I1 to keep it from-overheating. The combination of R11 and CR13 limits the output current of Q1.

The second transformer, T2, is for the +5 VDC supply. It is a 16 VCT transformer with circuit ground tied to the center tap. The transformer output is sent thru a full wave bridge rectifier and capacitively filtered. There is the same current protection as in the +15 VDC supply.

#### 4.9 POWER SUPPLY- REFERENCED TYPES

There are three Size 3 and Size 4 power supplies available which have reference voltage outputs: Positive or Negative Reference (voltage set as required) and a non-variable +10 Volt Reference.

The Positive Reference input is +15 VDC into a REF-01, (I4), +10 VDC reference regulator. The output of I4 goes into an OP-07 operational amplifier in a non-inverting mode. The gain of AR1 is adjustable for the required reference voltage.

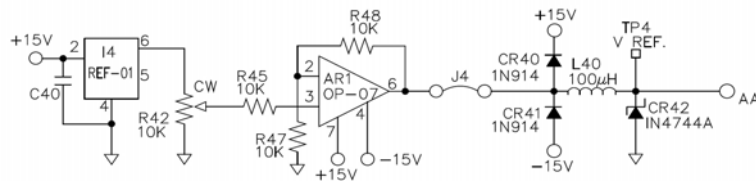

Figure 4.1

The Negative Reference input is +15 VDC into a REF-01 (I4), +10 VDC reference regulator. The output of I4 goes into AR1, an OP-07 operational amplifier is an inverting mode. The gain of AR1 is adjustable for the required reference voltage.

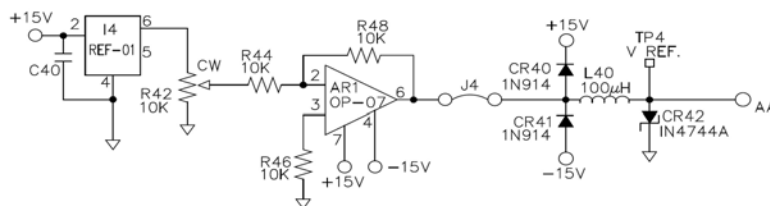

Figure 4.2

The +10 V Reference input is +15 VDC into a REF-01 (I4), +10 VDC reference regulator.

The output is adjusted by R40 for exactly +10 VDC.

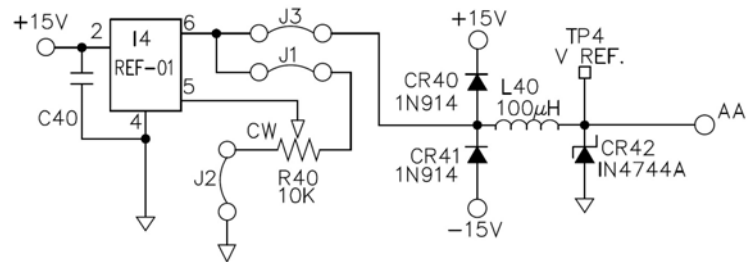

Figure 4.3

## V. OPERATING PROCEDURES

After the fiber optic cables and all electrical signal cables have been connected and secured, the system is ready for power. Connect a suitable cord to the AC power connector on each chassis. Turn ON the POWER switch, making sure the POWER LED comes on. If the LED does not come on, check all power connections back to the source. If the LED is on, the Fiber Optic Data Telemetry System is ready for use.

## VI. FIBER PREPARATION

### 6.1 EXTERNAL FIBER OPTIC CABLES

Despite the fact that fiber optic cables are flexible, they do break if stressed too much.

The following is the recommended method for repairing and preparing fiber optic cables.

Note that there are three separate procedures depending on type of connector used.

Two for fibers inside the Light Link chassis and one for both ends of external fibers.

#### EACH CABLE END OF AN EXTERNAL CABLE

The following equipment is needed for preparing external fiber optic cables.

Optic Fiber	Wire Cutter
Long Contact (1 per end)	200 grit sandpaper
Polishing bushing	600 grit sandpaper
Epoxy Cement	Polishing paper
Wire stripper	

Procedure:

1. Cut optical fiber to desired length plus 1/4".
2. Using wire stripper set to size 18AWG, strip fiber jacket back 7/8". Be careful not to scratch or nick the exposed fiber in any way.
3. Apply a drop of epoxy glue to the fiber and jacket.
4. Insert fiber firmly into long contact.
5. Crimp long contact onto fiber. Push on fiber while crimping to prevent fiber from backing out of contact during crimping.
6. Wipe off excess epoxy, taking care to keep epoxy off of the spring and retention clip.
7. Allow epoxy to harden overnight.
8. Using a sharp wire cutter, clip excess fiber from contact to about 1/32".



9. Insert contact into polishing bushing, and tighten bushing. Be sure to align retention clip on the contact with slots on polishing bushing. See Figure 6.1

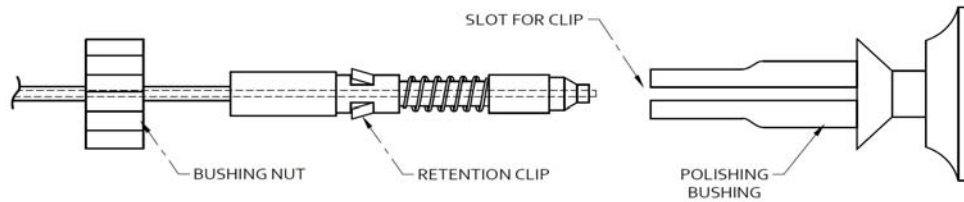

Figure 6.1

10. Polish the fiber end using the papers listed below. Use a figure 8 polishing motion.
- 200 grit dry sandpaper.
  - 600 grit dry sandpaper.
  - Wet Polishing paper: rinse often to remove any leftover coarser grit.
11. Remove polishing bushing and inspect the fiber end. The end should be shiny with a minimal number of scratches. Inspect the contact and make sure that none of the metal contact end has been polished off. If it has, then cut it off and begin again.

NOTE: The polishing bushing is good for only about 40 polishings (20 fibers). After this, the bushing should be discarded or it will damage end of contact. See Figure 6.2.

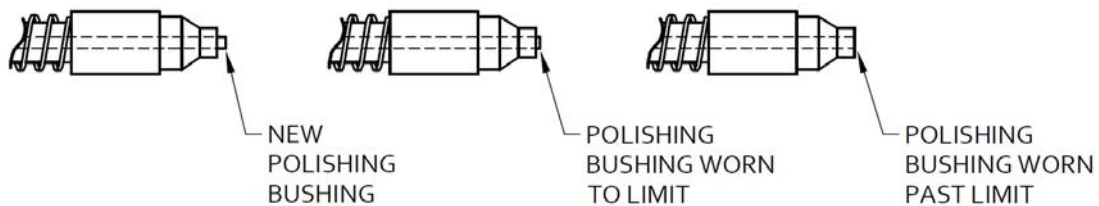

Figure 6.2

## 6.2 INTERNAL FIBER OPTIC CABLES

Despite the fact that fiber optic cables are flexible, they do break if stressed too much.

The following is the recommended method for repairing and preparing fiber optic cables.

Note that there are separate procedures for each type of connector used. Two for fibers inside the Light Link chassis and one for both ends of external fibers.

### CABLE ENDS OF AN INTERNAL CABLE

The following equipment will be needed for preparing fiber optic cables.

Optic Fiber	Wire Stripper
Long Contact	Wire Cutter
Ferrule Kit	200 grit Sandpaper
Splice Bushing	600 grit Sandpaper
Epoxy Cement	Polishing Bushing
Cyanoacrylate (Super Glue)	Polishing Paper
0.026" spacer (or 24AWG bus wire)	

#### 6.2.1 Procedure - Optic Cable Connector End:

1. Cut fiber to desired length, add 1/4".
2. Using wire stripper set to size 18AWG, strip fiber jacket back 7/8". Be careful not to scratch or nick the exposed fiber in any way.
3. Apply a drop of epoxy glue to the fiber and jacket.
4. Insert fiber firmly into long contact.
5. Crimp long contact onto fiber. Push on fiber while crimping to prevent fiber from backing out of contact during crimping.
6. Wipe off excess epoxy, taking care to keep epoxy off of the spring and retention clip.
7. Allow epoxy to harden overnight.
8. Using a sharp wire cutter, clip excess fiber from contact to about 1/32".

9. Insert contact into polishing bushing and tighten bushing. Be sure to align retention clip on the contact with the slots on the polishing bushing. See Figure 6.1 above.
  10. Polish the fiber end using the papers listed below. Use a figure 8 polishing motion.
    - a) 200 grit dry sandpaper.
    - b) 600 grit dry sandpaper.
    - c) Wet polishing paper: rinse often to remove any leftover coarser grit.
  11. Remove polishing bushing and inspect the fiber end. The end should be shiny with a minimal number of scratches. Inspect the contact and make sure that none of the contact end has been polished off. If it has, then cut it off and begin again.
- NOTE: The polishing bushing is good for only about 40 polishings (20 fibers). After this, the bushing should be discarded or it will damage end of contact . See Figure 6.2.
12. Apply cyanoacrylate around end of the contact. Be careful not to get glue on the fiber end.
  13. Press splice bushing onto end of contact. See Figures 6.3 and 6.4.

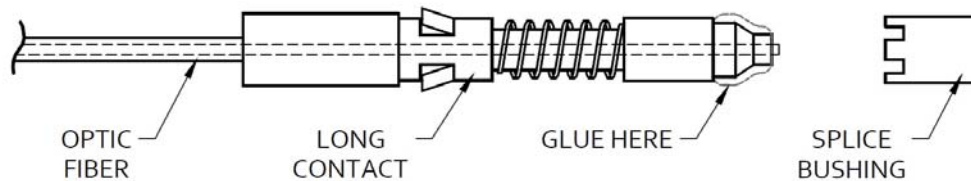

Figure 6.3

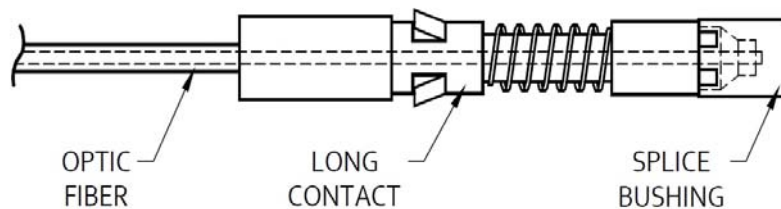

Figure 6.4

## 6.2.2 Procedure - PC Board End:

1. Using wire stripper set to size 18AWG, strip fiber jacket back 7/8". Be careful not to scratch or nick the exposed fiber in any way.
2. Slip the retaining spring and then crimp bushing onto fiber.
3. Apply a drop of epoxy glue to fiber and jacket. Be careful not to get glue on fiber end.
4. Insert fiber firmly into optic ferrule.
5. Place spacer or fold Bus Wire around ferrule to force a 0.026" gap . Pull brass crimp bushing into place next to spacer and crimp. While crimping, push on the end of the fiber to prevent it from backing out during crimping. See Figures 6.5 and 6.6.

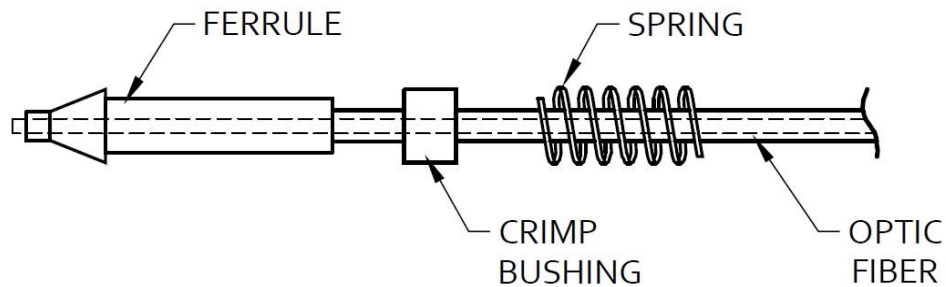

Figure 6.5

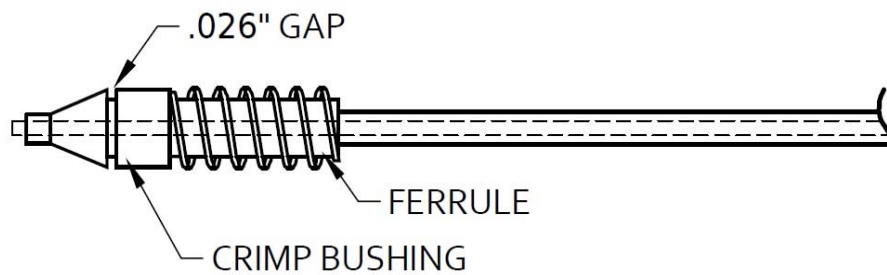

Figure 6.6

6. Wipe off excess epoxy.
7. Allow epoxy to harden overnight.
8. Clip excess fiber from ferrule to about 1/32". Use a sharp wire cutters.
9. Insert ferrule into polishing bushing.
10. Polish the fiber end using a figure 8 motion. Use the following paper schedule.
  - 1) 200 grit-dry
  - 2) 600 grit-dry
  - 3) Polishing Paper - wet: rinse paper often
11. Inspect the end of the fiber. It should be shiny with a minimal number of scratches.

NOTE: The polishing bushing is good for only about 40 polishings (20 fibers). After this, the bushing should be discarded or it will damage end of contact. See Figure 6.2.

## VII. APPENDICES

### 7.1 SUMMARY

#### Fiber Optic Data Telemetry System

Linearity: 0.1%

Resolution: 1:4000

Bandwidth: 10 Hz

Input Range: 0 to +1- VDC standard.

(100 mV sensitivity and/or negative polarity optional.)

Analog Signals: Optical transmitter accepts 0-10 VDC signals into 1M ohm input impedance. Receiver produces corresponding 0-10 VDC, 10 mA with 0.1% linearity.

Up to 32 dedicated ANALOG channels in largest chassis.

Status Signals: Optical transmitter accepts either contact closures or voltage: 0-1.4 VDC as logic ZERO and +4-24 VDC as logic ONE into an input impedance of 100k ohm.

Receiver output appears as relay contact closure or +24 VDC output voltage.

Up to 46 dedicated STATUS channels in largest chassis.

Cable - Fiber Optic type, 1 mm O.D. polymer up to 100 feet distance per cable.

Power Requirements: 115/230 VAC, 50/60 Hz, 160 Watts maximum.

Terminal Power Requirements: 120 VAC, 400 Hz, 80 Watts maximum.

## 7.2 DRAWINGS AND SCHEMATICS LISTING

Analog Transmitter (OTA)	
Schematic	2HS034540
P.C. Board/Component View	2HC000290
Parts List	2HR002470
Analog Receiver (ORA)	
Schematic	2HS034550
P.C. Board/Component View	2HC000190
Parts List	2HR002480
Status Transmitter (OTS)	
Schematic	2HS039160
P.C. Board/Component View	2HC000680
Parts List	2HR002770
Status Receiver (ORS & ORSHP)	
Schematic	2HS039170
P.C. Board/Component View	2HC000150
Parts List (ORS)	2HR002780
Parts List (ORSHP)	2HR002790
Receiver/Transmitter, Analog/Status (ORTAS)	
Schematic	2HS049280
P.C. Board/Component View	2HC000390
Parts List	2HR003800
Size 1 Power Supply	
2HA049370 Box Schematic	2HS049740
2HA057330 Box Schematic	2HS057170
Mother Board Schematic	2HS049940
P.C. Board Schematic (No Reference Voltage)	2HS039140
P.C. Board/Component View	2HR002720
Parts List, Size 1	2HR002720
Size 2 Power Supply	
2HA034660 Box Schematic	2HS035570
2HA057340 Box Schematic	2HS057190
2HA057540 Box Schematic	2HS057270
Mother Board Schematic	2HS032140
P.C. Board Schematic (No Reference Voltage)	2HS039140
P.C. Board/Component View	2HR002740
Parts List, Size 2	2HR002740

Size 3 Power Supply		
2HA057550 Box Schematic		2HS057280
2HA057560 Box Schematic		2HS057290
Mother Board Schematic		2HS032140
P.C. Board Schematic (No Reference Voltage)		2HS039150
P.C. Board/Component View		2HR002730
Parts List, Size 3		2HR002730
Size 4 Power Supply		
2HA057280 Box Schematic		2HS057150
2HA057290 Box Schematic		2HS057160
P.C. Board Schematic (+10V Reference Voltage)		2HS049670
P.C. Board/Component View		2HR002750
Parts List, Size 4		2HR002750
Size 4 Optical Card Box		
Schematic - Box		2HS056090
Mother Board Schematic		2HS032140

#### NEC FIBER OPTIC DATA TELEMETRY SYSTEM CONFIGURATION

Optic Chassis Assembly Configuration Template

Optic Cable Assembly Configuration Template

Custom Configurations for Uplink Chassis, Downlink Chassis, and Optic Cable:

Refer to "2HA0" part numbers for the specific system.



BOARD POSITION 1 BOARD TYPE ORA BOARD PART NUMBER 2HC111119

FRG #	FRGIC #	FRGIC PART #	FRGIC LENGTH	FRGIC HI	FRGIC LO	FRGIC CONN. #	FRGIC CONN. HI	FRGIC CONN. LO	FRGIC CONN. TYPE	FRGIC CONTROL	FRGIC VOLT. LEVEL	FRGIC COMMENTS
11A	1	16.5	1	14	X						10V	
11B	1	2	15								10V	
11C	1	2	16.5	1	3	16	X				10V	
12A	1	3	16.5	1	4	17					10V	
12B	1	4	16.5	1	5	18	X				10V	

BOARD POSITION 2 BOARD TYPE ORA BOARD PART NUMBER 2HC100119

FRG #	FRGIC #	FRGIC PART #	FRGIC LENGTH	FRGIC HI	FRGIC LO	FRGIC CONN. #	FRGIC CONN. HI	FRGIC CONN. LO	FRGIC CONN. TYPE	FRGIC CONTROL	FRGIC VOLT. LEVEL	FRGIC COMMENTS
21A	1	7	16.5	1	7	20	X				10V	
21B	1	8	16.5	1	9	22	X				10V	

BOARD POSITION 3 BOARD TYPE ORA BOARD PART NUMBER 2HC211119

FRG #	FRGIC #	FRGIC PART #	FRGIC LENGTH	FRGIC HI	FRGIC LO	FRGIC CONN. #	FRGIC CONN. HI	FRGIC CONN. LO	FRGIC CONN. TYPE	FRGIC CONTROL	FRGIC VOLT. LEVEL	FRGIC COMMENTS
31A	1	13	15	2	1	14	X				10V	
31B	1	14	15	2	3	16	X				10V	
32A	1	15	15	2	5	18	X				10V	
32B	1	16	15	2	6	19	X				10V	

BOARD POSITION 4 BOARD TYPE ORA BOARD PART NUMBER 2HC244119

FRG #	FRGIC #	FRGIC PART #	FRGIC LENGTH	FRGIC HI	FRGIC LO	FRGIC CONN. #	FRGIC CONN. HI	FRGIC CONN. LO	FRGIC CONN. TYPE	FRGIC CONTROL	FRGIC VOLT. LEVEL	FRGIC COMMENTS
41A	1	19	15	2	7	20	X				10V	
41B	1	20	15	2	9	22	X				10V	
42A	1	21	15	2	10	23	X				11V	
42B	1	22	15	2	12	25	X				11V	

BOARD POSITION 5 BOARD TYPE ORA BOARD PART NUMBER 2HC211119

FRG #	FRGIC #	FRGIC PART #	FRGIC LENGTH	FRGIC HI	FRGIC LO	FRGIC CONN. #	FRGIC CONN. HI	FRGIC CONN. LO	FRGIC CONN. TYPE	FRGIC CONTROL	FRGIC VOLT. LEVEL	FRGIC COMMENTS
51A	2	1	13.5	3	1	14	X				10V	
51B	2	2	13.5	3	2	15					10V	
52A	2	3	13.5	3	5	18	X				10V	
52B	2	4	13.5	3	6	19	X				10V	

BOARD POSITION 6 BOARD TYPE ORTAS BOARD PART NUMBER 2HC313129

FRG #	FRGIC #	FRGIC PART #	FRGIC LENGTH	FRGIC HI	FRGIC LO	FRGIC CONN. #	FRGIC CONN. HI	FRGIC CONN. LO	FRGIC CONN. TYPE	FRGIC CONTROL	FRGIC VOLT. LEVEL	FRGIC COMMENTS
61A	2	7	13.5	3	7	20	X				24V	
61B	2	8	13.5	3	9	22	X				10V	
62A	2	9	13.5	3	11	24					10V	
62B	2	10	13.5	3	12	25	X				10V	

BOARD POSITION 7 BOARD TYPE ORTAS BOARD PART NUMBER 2HC313129

FRG #	FRGIC #	FRGIC PART #	FRGIC LENGTH	FRGIC HI	FRGIC LO	FRGIC CONN. #	FRGIC CONN. HI	FRGIC CONN. LO	FRGIC CONN. TYPE	FRGIC CONTROL	FRGIC VOLT. LEVEL	FRGIC COMMENTS
71A	2	13	12	4	1	14	X				24V	
71B	2	14	12	4	3	15					10V	
72A	2	15	12	4	4	17					10V	
72B	2	16	12	4	5	18	X				10V	

BOARD POSITION 8 BOARD TYPE ORTAS BOARD PART NUMBER NOT USED

FRG #	FRGIC #	FRGIC PART #	FRGIC LENGTH	FRGIC HI	FRGIC LO	FRGIC CONN. #	FRGIC CONN. HI	FRGIC CONN. LO	FRGIC CONN. TYPE	FRGIC CONTROL	FRGIC VOLT. LEVEL	FRGIC COMMENTS
81A	2	17	12	4	6	19	X				10V	
81B	2	18	12	4	7	20	X				10V	
81C	2	19	12	4	8	21					10V	
81D	2	20	12	4	9	22	X				10V	
81E	2	21	12	4	10	23					10V	
81F	2	22	12	4	11	24					10V	
81G	2	23	12	4	12	25					10V	

BOARD SUMMARY QUANTITY TOTALS

TYPE	DWG NUMBER	REF NUMBER	BOARDS	CHANNELS	COMMENTS
OTA	8-3-23	8-6-247			
ORA	8-3-19	8-6-248			
OTS	8-3-68	8-6-277			
ORS	8-3-15	8-6-278			
ORSHIP	8-3-18	8-6-279			
ORTAS	8-3-59	8-6-380			

FRGIC #	FRGIC PART #	FRGIC LENGTH	FRGIC HI	FRGIC LO	FRGIC CONN. #	FRGIC CONN. HI	FRGIC CONN. LO	FRGIC CONN. TYPE	FRGIC CONTROL	FRGIC VOLT. LEVEL	FRGIC COMMENTS
21A	1	7	16.5	1	7	20	X				10V
21B	1	8	16.5	1	9	22	X				10V
21C	1	9	16.5	1	10	23					10V
21D	1	10	16.5	1	11	24					10V
21E	1	11	16.5	1	12	25					10V
21F	1	12	16.5	1	13	26					10V
21G	1	13	16.5	1	14	27					10V
21H	1	14	16.5	1	15	28					10V
21I	1	15	16.5	1	16	29					10V
21J	1	16	16.5	1	17	30					10V
21K	1	17	16.5	1	18	31					10V
21L	1	18	16.5	1	19	32					10V
21M	1	19	16.5	1	20	33					10V
21N	1	20	16.5	1	21	34					10V
21O	1	21	16.5	1	22	35					10V
21P	1	22	16.5	1	23	36					10V
21Q	1	23	16.5	1	24	37					10V
21R	1	24	16.5	1	25	38					10V
21S	1	25	16.5	1	26	39					10V
21T	1	26	16.5	1	27	40					10V
21U	1	27	16.5	1	28	41					10V
21V	1	28	16.5	1	29	42					10V
21W	1	29	16.5	1	30	43					10V
21X	1	30	16.5	1	31	44					10V
21Y	1	31	16.5	1	32	45					10V
21Z	1	32	16.5	1	33	46					10V
22A	2	1	13.5	3	1	14	X				10V
22B	2	2	13.5	3	2	15					10V
22C	2	3	13.5	3	5	18	X				10V
22D	2	4	13.5	3	6	19	X				10V
22E	2	5	13.5	3	7	20	X				10V
22F	2	6	13.5	3	8	21					10V
22G	2	7	13.5	3	9	22	X				10V
22H	2	8	13.5	3	11	24					10V
22I	2	9	13.5	3	12	25	X				10V
22J	2	10	13.5	3	13	26					10V
22K	2	11	13.5	3	14	27					10V
22L	2	12	13.5	3	15	28					10V
22M	2	13	13.5	3	16	29					10V
22N	2	14	13.5	3	17	30					10V
22O	2	15	13.5	3	18	31					10V
22P	2	16	13.5	3	19	32					10V
22Q	2	17	13.5	3	20	33					10V
22R	2	18	13.5	3	21	34					10V
22S	2	19	13.5	3	22	35					10V
22T	2	20	13.5	3	23	36					10V
22U	2	21	13.5	3	24	37					10V
22V	2	22	13.5	3	25	38					10V
22W	2	23	13.5	3	26	39					10V
22X	2	24	13.5	3	27	40					10V
22Y	2	25	13.5	3	28	41					10V
22Z	2	26	13.5	3	29	42					10V
23A	2	27	13.5	3	30	43					10V
23B	2	28	13.5	3	31	44					10V
23C	2	29	13.5	3	32	45					10V
23D	2	30	13.5	3	33	46					10V
23E	2	31	13.5	3	34	47					10V
23F	2	32	13.5	3	35	48					10V
23G	2	33	13.5	3	36	49					10V
23H	2	34	13.5	3	37	50					10V
23I	2	35	13.5	3	38	51					10V
23J	2	36	13.5	3	39	52					10V
23K	2	37	13.5	3	40	53					10V
23L	2	38	13.5	3	41	54					10V
23M	2	39	13.5	3	42	55					10V
23N	2	40	13.5	3	43	56					10V
23O	2	41	13.5	3	44	57					10V
23P	2	42	13.5	3	45	58					10V
23Q	2	43	13.5	3	46	59					10V
23R	2	44	13.5	3	47	60					10V
23S	2	45	13.5	3	48	61					10V
23T	2	46	13.5	3	49	62					10V
23U	2	47	13.5	3	50	63					10V
23V	2	48	13.5	3	51	64					10V
23W	2	49	13.5	3	52	65					10V
23X	2										

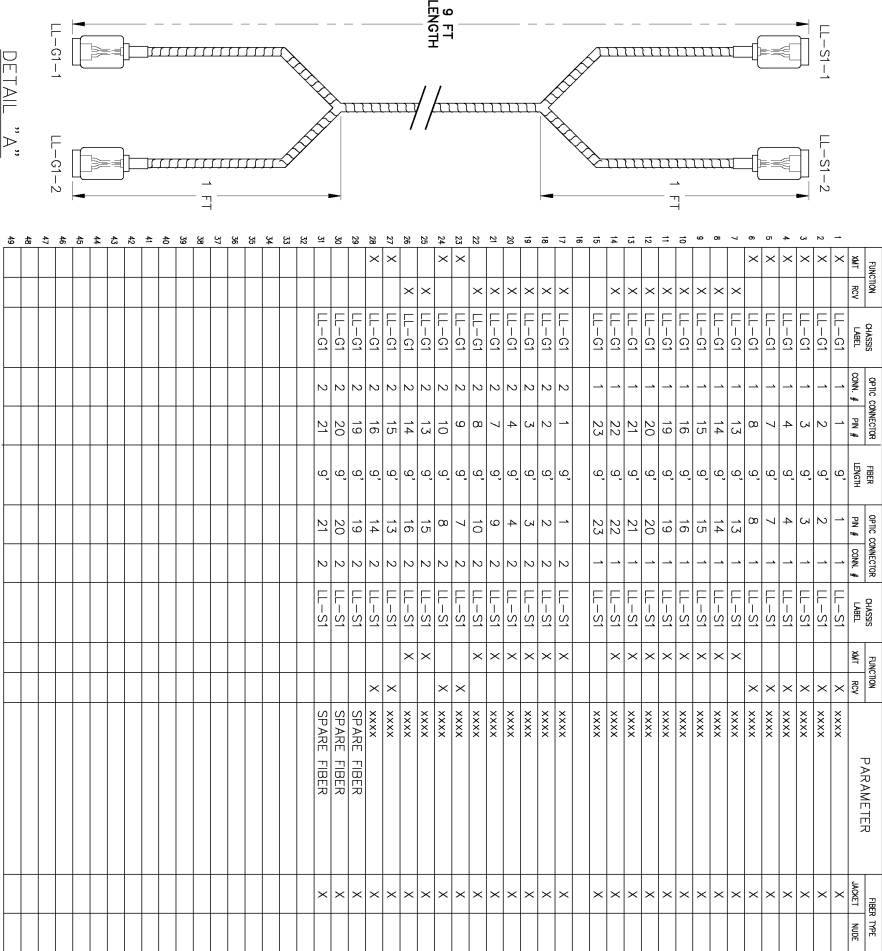

FUNCTION	CLASS LABEL	OPTIC CONN. / OPT. #	FIBER LENGTH	OPTIC CONN. / OPT. #	CLASS LABEL	FUNCTION	PARAMETER	FIBER TYPE
MFR	REV					MFR		NUDE
1	X	LL-GI	1	2	1	LL-SI	X	X
2	X	LL-GI	1	2	2	LL-SI	X	X
3	X	LL-GI	1	3	3	LL-SI	X	X
4	X	LL-GI	1	4	4	LL-SI	X	X
5	X	LL-GI	1	7	7	LL-SI	X	X
6	X	LL-GI	1	8	8	LL-SI	X	X
7	X	LL-GI	1	13	13	LL-SI	X	X
8	X	LL-GI	1	14	14	LL-SI	X	X
9	X	LL-GI	1	15	15	LL-SI	X	X
10	X	LL-GI	1	16	16	LL-SI	X	X
11	X	LL-GI	1	19	19	LL-SI	X	X
12	X	LL-GI	1	20	20	LL-SI	X	X
13	X	LL-GI	1	21	21	LL-SI	X	X
14	X	LL-GI	1	22	22	LL-SI	X	X
15	X	LL-GI	1	23	23	LL-SI	X	X
16	X	LL-GI	2	1	2	LL-SI	X	X
17	X	LL-GI	2	2	2	LL-SI	X	X
18	X	LL-GI	2	3	3	LL-SI	X	X
19	X	LL-GI	2	4	4	LL-SI	X	X
20	X	LL-GI	2	7	7	LL-SI	X	X
21	X	LL-GI	2	8	8	LL-SI	X	X
22	X	LL-GI	2	9	9	LL-SI	X	X
23	X	LL-GI	2	10	10	LL-SI	X	X
24	X	LL-GI	2	13	13	LL-SI	X	X
25	X	LL-GI	2	14	14	LL-SI	X	X
26	X	LL-GI	2	15	15	LL-SI	X	X
27	X	LL-GI	2	16	16	LL-SI	X	X
28	X	LL-GI	2	19	19	LL-SI	X	X
29	X	LL-GI	2	20	20	LL-SI	X	X
30	X	LL-GI	2	21	21	LL-SI	X	X
31	X	LL-GI	2	21	21	LL-SI	X	X
32								
33								
34								
35								
36								
37								
38								
39								
40								
41								
42								
43								
44								
45								
46								
47								
48								
49								

- NOTES:**
- ASSEMBLY CONSISTS OF 2 CABLES CONTINUOUSLY SPIRAL WRAPPED TOGETHER. USE PROPER DIAMETER OF WRAP (ITEMS 4 & 5).
  - CABLE BETWEEN 8-0-5765 AND 8-0-5766.
  - CABLE IS NOT 1:1.

CHASSIS IDENTIFICATION  
 WORK ORDER NO. 6-115-13 WORK ORDER NO. \_\_\_\_\_  
 SYSTEM DWG. NO. 2AA073910 SYSTEM DWG. NO. \_\_\_\_\_

CHASSIS PART NUMBER	CHASSIS LABEL	CHASSIS PART NUMBER	CHASSIS LABEL
2HA057650	LL-GI		
2HA057650	LL-SI		

BASIC EXTERNAL CABLE ASSEMBLY DRAWING NUMBER  
 8-0- 811, OPT. 1

FIBER			
# RUNS	LENGTH	TOTAL FT	NUDE/JKT
30	9	270	JACKET

NO.	REGION	BY	DATE	CHKD	DATE	DRWN	DATE
						2/28/99	9/9/99
TOLERANCES AND FINISH UNLESS OTHERWISE SPECIFIED							
FINISH	SCALE	DRAWN	INSTRUMENT	SCALE	DATE		
AS APPEARED	1:1	NTS	9/9/99	NTS			
MULTIPLE MATERIALS SEE PARTLIST							
	2HA0xxxxx						

NATIONAL ELECTROSTATICS CORPORATION  
 MOONINGLOW - ASSEMBLY  
 Template

